



**Elevation**  
Packaging & Equipment

9 4 5 0

**SIMPLY EFFICIENT**



PRODUCT CODING - SMALL CHARACTER INKJET - 9450

Elevation Packaging & Equipment, Inc.  
Omaha, Nebraska 68131  
402.740.1512 - [www.elevationpkg.com](http://www.elevationpkg.com) - [info@elevationpkg.com](mailto:info@elevationpkg.com)

 **markem-image**  
A DOVER COMPANY



If improving the efficiency of your production process is one of your priorities, the new 9450 coder was engineered for you. The new Markem-Imaje 9450 is designed to be fully **available**, keep up with **your line speed** and **secure each of your products with the right code!**

## PRINT MORE. EFFICIENCY BUILT IN ■ ■ ■

Relax for 5 years<sup>(1)</sup> with our **LONGEVITY** service pack

### PROVEN ROBUSTNESS

**Maximize your production performance. 99.9% availability rate<sup>(2)</sup>.** Access to our local team of engineers that will assist and provide you with genuine spares and consumables.

**Smart design. TCO included.** Engineered to lower your TCO, the 9450 offers you up to 20% reduction<sup>(3)</sup> in consumable use and energy consumption (no need for plant air) and optimizes your waste-related expenses.

**Hygienic design. Efficient washdown (IP56 standard, IP66 optional).** Install it anywhere you want! Wash it down with pressured water and industrial detergent and make sure your hygiene standards are met.

**Clean less, gain time.** New stainless steel monoblock printhead design makes head cleaning easy and trouble-free, when necessary.

**Move it or store it away for weeks.** Its automatic cleaning system will ensure jet stability remains perfect when restarting.

### EASY AND MISTAKE-PROOF OPERATION

**Get it started in just a few minutes and run it 3 shifts non-stop.** Tactile navigation is easy and straightforward.

**Smart consumable system. No set-up required.** With our innovative cartridge design, cartridge-related mistakes are no longer possible. Consumable management is automatic, clean and fully secure. Don't risk printing your product with the wrong ink or plugging in the wrong cartridge.

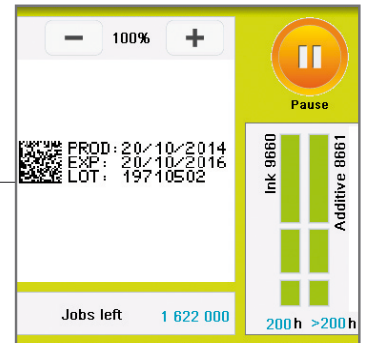

**Don't stop production. Accurate consumable level display** and efficient consumable replacement while in use will make sure you don't lose precious production time!



(1) Warranty on parts only. See conditions defined by your local Markem-Imaje subsidiary.  
(2) Please contact your local Markem-Imaje subsidiary for more information on our service packs.  
(3) Compared to other brands in the same category.

# INCREASE YOUR PRINTING CAPABILITIES. 20% FASTER<sup>(3)</sup> ■ ■ ■

Wide variety of code and consumable options will give you the traceability you need and support your marketing-related initiatives.



## CHOOSE THE CODE YOU NEED TO CARRY OUT YOUR MARKETING OBJECTIVES

**Promotional coding and serialization functions** to support your marketing initiatives and help you easily implement them from the start. Wide code choice including barcodes, multi-line, logos, language-specific characters (Arabic, Japanese, Chinese, etc.) at the resolution and size you want.



## ACHIEVE YOUR TRACEABILITY AND SUSTAINABILITY GOALS

**Large choice of high adhesion, high contrast or colored inks** to ensure your product is coded right, contrast is guaranteed and code does not rub off. Also available, a line of **environmentally-friendly ink solutions** to support your sustainability policy as well as anti-counterfeiting solutions.



# ENHANCED USER EXPERIENCE TO PREVENT PRODUCT RECALLS AND WASTE ■■■

One step editing. Job secured

## STANDARD COLOR TOUCH SCREEN

**Enhanced and proven user intuitiveness** starts with the tip of your finger on the 7-inch touch screen.



## CONFIGURE THE JOB AND LOCK IT

**Your local language online guiding system** will lead you through the steps to ensure your code is what you want it to be.

## EASY RUNNING COST TRACKING VIA SMART MONITORING SYSTEM

**User interface menus provide access** to previous maintenance and production history including availability rate, additive consumption as well as real-time warnings.

**Operator access and password management** can be configured to your needs offering more control.



## MARK & READ IT. CODE SECURED

**Code integrity is automatically checked** via the new embedded Mark and Read vision system<sup>(4)</sup>. **Full control.** Limited operator time, limited product waste.



# 9450

## Designed to support your Overall Equipment Efficiency improvement

**Don't let your printer slow you down.** The 9450 prints 20% faster than any other printer on the market in its category.

**Don't compromise on quality or risk traceability errors.** Our new Mark and Read system will make sure every code is checked, every single time and your product is safely identified.

**Master your costs.** Designed to lower your total cost of ownership, the 9450 helps you benefit from all the latest technical enhancements to optimize consumable consumption as well as maintenance and waste-related expenses.

**Developed along your lines, the 9450 can be easily integrated and managed centrally** through the Markem-Imaje CoLOS software package. Automatic monitoring and central management will make coding activities transparent and help you optimize your overall equipment efficiency.

## OUR SERVICE PACKS

	PREMIUM PACK	SERENITY PACK	LONGEVITY PACK
Eligible printers	New or existing 9410/9450	New 9410/9450	New 9410/9450
Full warranty length - 18 months	●	●	●
• Breakfix parts	●	●	●
• Onsite labor	●	●	●
• Travel	●	●	●
• MI-Preferred support	●	●	●
Main circuit parts - 5 year warranty (Part only. Labor included during the initial 18-month warranty period)	●	●	●
Full warranty extension: 36, 48, 60 months	●	●	-
MI Prevent (predictive maintenance)	●	-	-
Start-up service (including operator training)	Available	Available	Available
<b>SMILE</b>			
3 to 5 year printer leasing	Available	Available	-
3 to 5 year consumable supply	Available	-	-
MI Secure (availability commitment)	Available	-	-

## THE CODE YOU WANT

### TO ENSURE SAFETY AND TRACEABILITY

Solutions include anti-counterfeiting inks, permanent inks with high levels of contrast and adhesion available for numerous substrates



### TO PROMOTE YOUR BRAND AND SUPPORT YOUR CAMPAIGNS

Solutions include embedded promotional coding and serialization functions

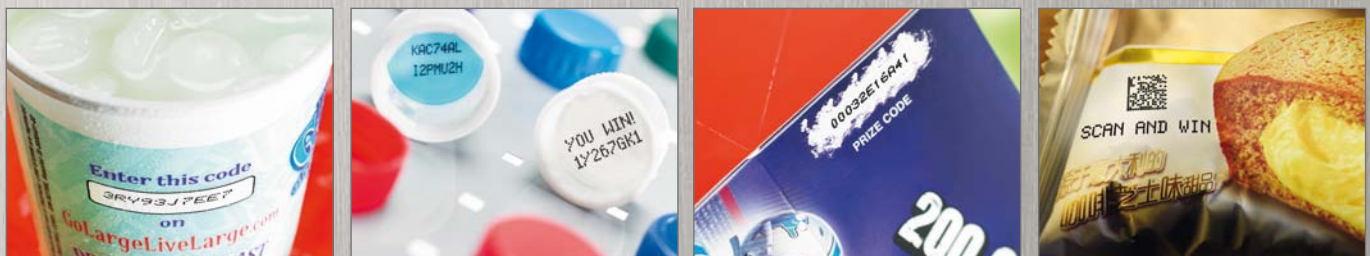

### TO PROTECT YOUR BRAND

Solutions include environmentally-friendly inks, thermochromic inks as well as numerous advanced logo options



## PRINT FEATURES

- ▶ Mono-jet printhead
- ▶ G head (printing resolution: 71 dpi)
- ▶ M head (printing resolution: 115 dpi)
- ▶ Up to 5 lines of print
- ▶ Print speed: up to 6.6 m/s
- ▶ Font height from 5 to 32 dots
- ▶ Character height: from 1.2 to 11.2 mm
- ▶ Wide choice of 1D and 2D barcodes: EAN8/EAN13/UPCA/UPCE barcodes, code 39, interleaved 2 of 5, Datamatrix, QR code
- ▶ Wide choice of characters: Latin, Arabic, Cyrillic, Hebrew, Japanese, Chinese, Korean, etc.

## OPERATIONS

- ▶ Message library (up to 1000 messages)
- ▶ International operator/machine interface with a wide choice of languages
- ▶ WYSIWYG 7-inch wide touch screen: realtime display of remaining print capacity expressed in hours and number of messages; integrated assistance and alert system; simplified message printing and management; creation of user profiles; tracking of consumption and printer availability
- ▶ USB and SD ports
- ▶ Jet Speed Control guarantees marking quality
- ▶ Automatic selection of fonts, depending on print speed and printhead/object distance
- ▶ Broad range of inks: multi-use, high performance; alcohol-based, ketone-free and MEK-free inks
- ▶ Sealed 0.8-liter cartridges with foolproofing system
- ▶ Quick connect/disconnect of accessories (photocell, alarm and encoder)
- ▶ Parent/child connectivity
- ▶ Ethernet connectivity
- ▶ Specific date management (rounding date function)

## OTHER CHARACTERISTICS

- ▶ Weight: 25 kg
- ▶ Table-top or vertical mounting
- ▶ Ultra-flexible 3-meter umbilical cable
- ▶ Stainless steel cabinet and printhead case
- ▶ Dust/humidity protection rating: IP56 not requiring plant air
- ▶ Operating temperature range: 0 to 40°C depending on ink used
- ▶ Humidity: 10 to 90% non-condensing
- ▶ Electrical power supply: 100-120 V or 200-240 V with automatic switching; frequency 50/60 Hz; power 60 VA

## OPTIONS

- ▶ Promotional coding and Mark and Read
- ▶ Ultra-flexible 6-meter umbilical cable
- ▶ IP66 protection (requires plant air)
- ▶ Ultrarapid mode for high-speed printing
- ▶ Printhead pressurization kit
- ▶ RS-232/422 connectivity, parallel interface, many I/O possibilities to enable remote operation

## ACCESSORIES

- ▶ Printer supports: stands (stainless steel or aluminum), table or wall mounting brackets
- ▶ Printhead supports: stand (stainless steel) and choice of brackets
- ▶ Photocells
- ▶ Encoders
- ▶ Alarm beacons (24 V)

## SOFTWARE

- ▶ Compatible with CoLOS Create Professional and CoLOS Enterprise
- ▶ Logo creation with CoLOS Graphics

### Printhead

Minimum radius of curvature of the umbilical:

- Static: 100 (3.93 ")

- Dynamic: 150 (5.90 ")

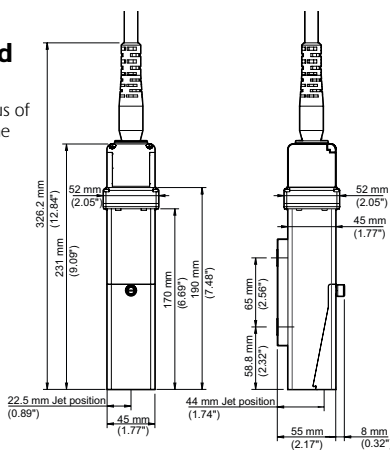

### Cabinet

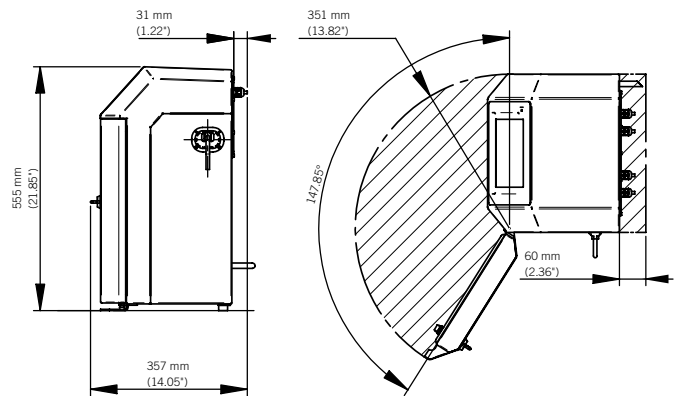
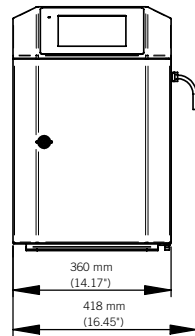

We reserve the right to amend the design and/or specifications of our products without notice.



Omaha, Nebraska 68131

402.740.1512 - [www.elevationpkg.com](http://www.elevationpkg.com) - [info@elevationpkg.com](mailto:info@elevationpkg.com)



A DOVER COMPANY

To learn more, visit [www.markem-imaje.com](http://www.markem-imaje.com)

